

Instruction Sheet

FIRST RESPONDER GUIDE - International® eMV™ Series

NAVISTAR®

4328810R1

Purpose

The purpose of this document is to provide detailed instruction on the following for first responders:

- Safety information
- High-voltage labels
- Personal Protection Equipment (PPE)
- Identify the vehicle: exterior
- Identify the vehicle: interior
- Identify the vehicle: under hood
- Overview: vehicle systems and components
- High-voltage battery
- Drive motor
- High-voltage cables
- Immobilization
- Disable direct hazards
- Stored energy / liquids
- Hazardous material emergency cleanup
- In case of fire
- In case of submersion
- Towing / transportation / storage
- Important additional information

Safety Information

NOTE: Certain warnings may be repeated throughout this manual.

 **WARNING:** To prevent personal injury and / or death, remove all jewelry such as watches, necklaces, and earrings. Remove all metal objects that are conductors of electricity.

 **WARNING:** To prevent personal injury and / or death, **ALWAYS** approach the vehicle from the sides whenever possible to stay out of potential travel path. It may be difficult to determine if the vehicle is running due to lack of engine noise.

 **WARNING:** To prevent personal injury and / or death, or damage to property, remove any charge cable from the vehicle, turn ignition OFF, set parking brake, and install wheel chocks to prevent vehicle from moving in either direction during further action.

 **WARNING:** To prevent personal injury and / or death, do not touch the high-voltage system or any **ORANGE** device without wearing appropriate high-voltage Personal Protection Equipment (PPE). The PPE should include:

- a. Class 0 electrical insulating gloves, safety goggles, and Electrical Hazard (EH) rated safety shoes or boots, which must be at least appropriate up to 1,000 volts.
- b. A non-conductive object, about 5 ft (1.5 m) long, to safely push someone away from the vehicle if they accidentally come in contact.

 **WARNING:** To prevent personal injury and / or death, turn OFF the 12V disconnect switch and high-voltage disconnect switch before interacting with a damaged vehicle.

 **WARNING:** To prevent personal injury and / or death, **ALWAYS REMEMBER** the 12 Volt Battery Disconnect Switch only disables the vehicle 12 volt system, **NOT** the high-voltage battery system.

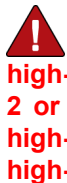
 **WARNING:** To prevent personal injury and / or death, **ALWAYS REMEMBER** that turning OFF the high-voltage disconnect switch will not dissipate voltage inside the high-voltage batteries or in level 2 or 3 high-voltage cables. **ALWAYS ASSUME** the high-voltage batteries, high-voltage cables, and high-voltage components remain live and dangerous. Contact with the high-voltage battery pack or high-voltage component internals may result in serious personal injury or death.

 **WARNING:** To prevent personal injury and / or death, handle a submerged vehicle with appropriate Personal Protection Equipment (PPE). Consider the entire vehicle as energized.

 **WARNING:** To prevent personal injury and / or death, always wear full Personal Protection Equipment (PPE), including Self-Contained Breathing Apparatus (SCBA) when fire is involved. Fires in crash-damaged electric vehicles could emit toxic or combustible gasses. Small amounts of eye, skin, or lung irritants may be present. If exposed, rinse with large amounts of water for 10-15 minutes. Consider the entire vehicle as energized.

 **WARNING:** To prevent personal injury and / or death, **NEVER** cut or attempt to breach high-voltage batteries, high-voltage components, or high-voltage wiring.

 **WARNING:** To prevent personal injury and / or death, pay attention to secondary fire events. Even days later secondary fire events cannot be excluded.

High-Voltage Labels



0000469454

Figure 1. Extract of Available High-Voltage Labels Throughout the Entire Vehicle

Various high-voltage components are installed throughout the entire vehicle. A triangle with a lightning bolt is used to identify high-voltage components. The lightning triangle can be single or part of a combination. Also, any vehicle components that are ORANGE in color and / or ORANGE with stripes identify high-voltage components.

High-voltage components in the vehicle are divided into three levels / zones. Only components at level 1 / zone 1 are isolated after the high-voltage disconnect switch is turned OFF. Components in zone 2 and zone 3 remain live.

High-Voltage Labels (cont.)

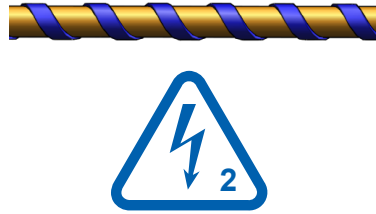

0000469818

Figure 2. Level 2 / Zone 2: High-voltage cables are ORANGE with BLUE striping and have WHITE and BLUE safety flags.

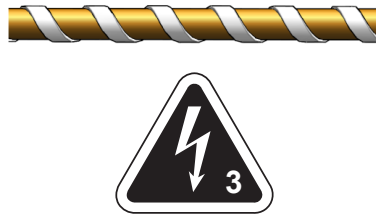

0000469819

Figure 3. Level 3 / Zone 3: High-voltage cables are ORANGE with WHITE striping and have BLACK and WHITE safety flags.

⚠ WARNING: To prevent personal injury and / or death, ALWAYS REMEMBER that turning OFF the high-voltage disconnect switch will not dissipate voltage inside the high-voltage batteries or in level 2 or 3 high-voltage cables. ALWAYS ASSUME the high-voltage batteries, high-voltage cables, and high-voltage components remain live and dangerous unless high voltage is isolated and the isolation is verified. Contact with the high-voltage battery pack or high-voltage component internals may result in serious personal injury or death.

Components in high-voltage zone 2 and high-voltage zone 3 remain live after the high-voltage disconnect switch is turned OFF. These zones are mostly located between the frame rails on the underside of the vehicle and are labeled as indicated in Figure 2 and Figure 3.

High-Voltage Labels (cont.)

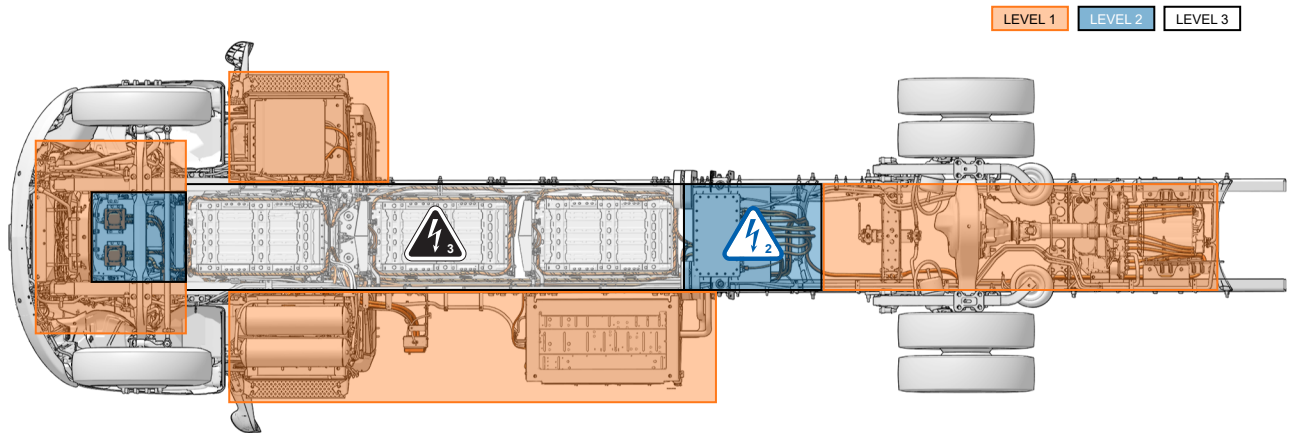

0000470783

Figure 4. High-Voltage Isolation Levels / Zones (Viewed from Bottom)

The level 1, 2, and 3 zones are located as shown in Figure 4.

Personal Protection Equipment (PPE)



WARNING: To prevent personal injury and / or death, remove all jewelry such as watches, necklaces, and earrings. Remove all metal objects that are conductors of electricity.



WARNING: To prevent personal injury and / or death, do not touch the high-voltage system or any **ORANGE** device without wearing appropriate high-voltage Personal Protection Equipment (PPE). The PPE should include:

- a. Class 0 electrical insulating gloves, safety goggles, and Electrical Hazard (EH) rated safety shoes or boots, which must be at least appropriate up to 1,000 volts.
- b. A non-conductive object, about 5 ft (1.5 m) long, to safely push someone away from the vehicle if they accidentally come in contact.

A vehicle with **DAMAGED** high-voltage components or with **UNKNOWN** safety status should only be handled by special trained and equipped personnel. The Personal Protection Equipment must be at least appropriate up to 1,000 volts. Consider the entire vehicle as energized.

Always wear full appropriate Personal Protection Equipment (PPE), including Self-Contained Breathing Apparatus (SCBA), when fire is involved or the vehicle was submerged due to the high risk of reignition.

On an International® eMV™ Series **WITHOUT** any damage, the ignition, 12V disconnect switch, and high-voltage disconnect switch are designed to be operated without any special high-voltage Personal Protection Equipment (PPE). Do not touch any other high-voltage component or **ORANGE** colored device without appropriate protection.

Identify the Vehicle: Exterior

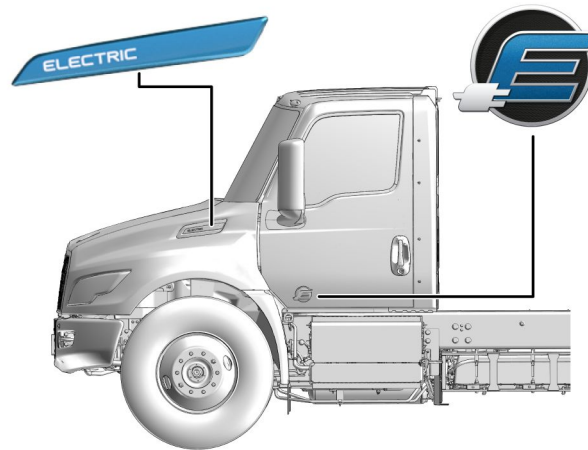

0000470903

Figure 5. Exterior Badges

The International® eMV™ Series can be distinguished on the exterior from common truck models by badges on the left and right front doors and by a BLUE **ELECTRIC** badge on either side of the hood. The positioning of these badges is identical for both the left side and the right side of the vehicle.

Identify the Vehicle: Under Hood

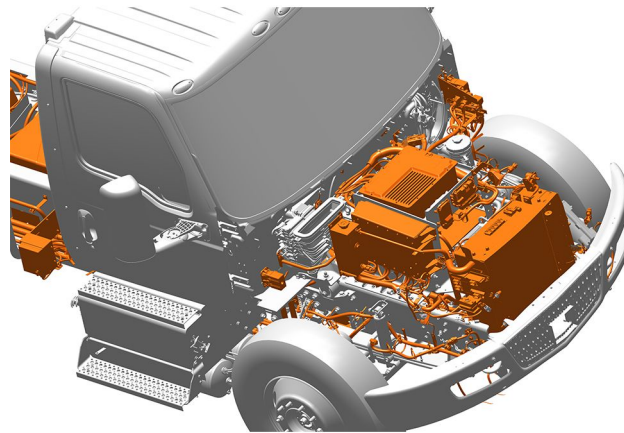

0000469812

Figure 6. Under Hood

Under hood, the International® eMV™ Series has several high-voltage modules, which can be distinguished by the ORANGE cables and high-voltage labels.

Identify the Vehicle: Interior

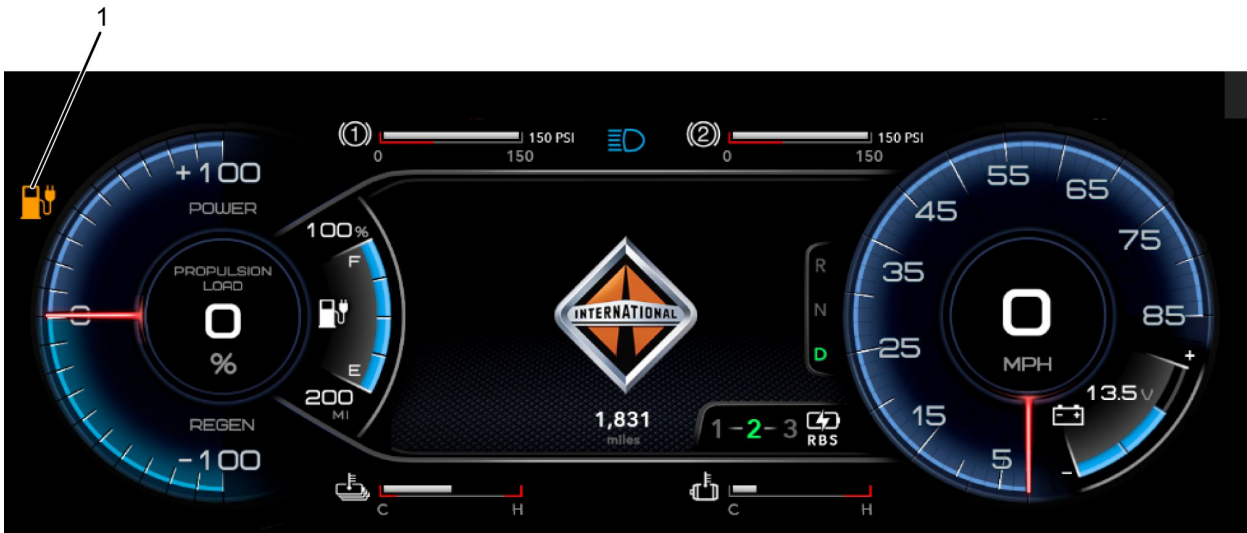

0000471545

Figure 7. Cluster

1. Charging station icon

The International® eMV™ Series can be distinguished from common medium duty truck models by the charging station icon (Figure 7, Item 1) on the top left of the instrument cluster.

Vehicle Systems and Components

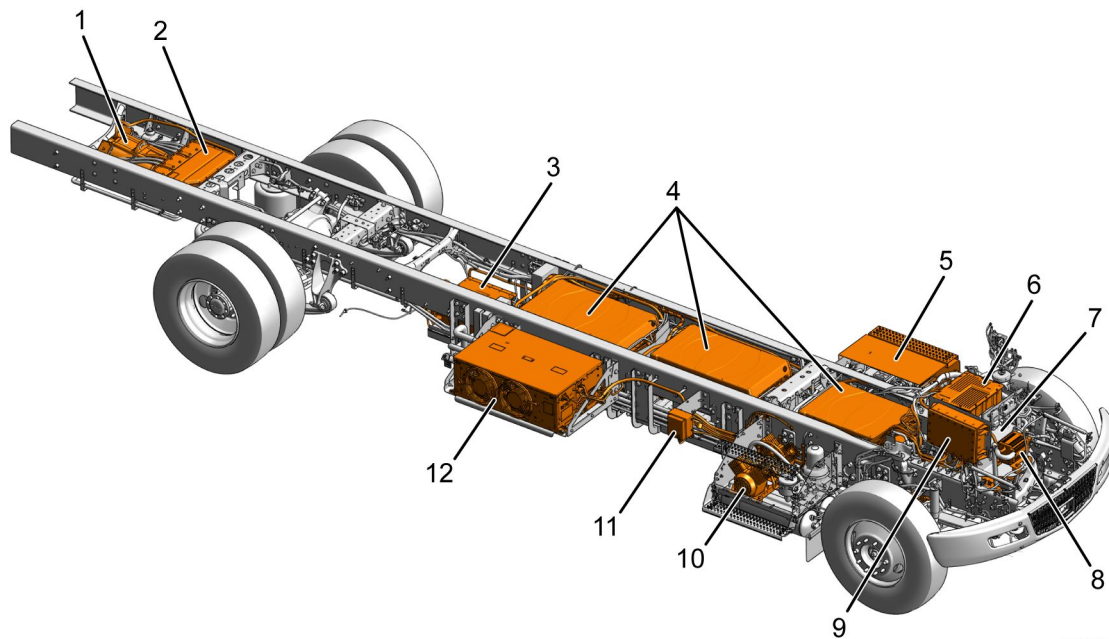

0000471161

Figure 8. Vehicle Overview

1. Drive motor
2. Traction Power Inverter Module (TPIM)
3. S-box and High-Voltage Distribution Module (HVDM)
4. High-voltage battery stack (3)
5. DCDC converters (DCDC) and 12V batteries (inside stair box)
6. 2-in-1 inverter
7. On-Board Charger (OBC) (2) (under Item 6)
8. High-voltage power steering pump (located behind front cooling system)
9. High-Voltage Distribution Unit (HVDU)
10. High-voltage air compressor (inside stair box)
11. Charge port (high-voltage)
12. Battery Thermal Management System (BTMS)

Vehicle Systems and Components (cont.)

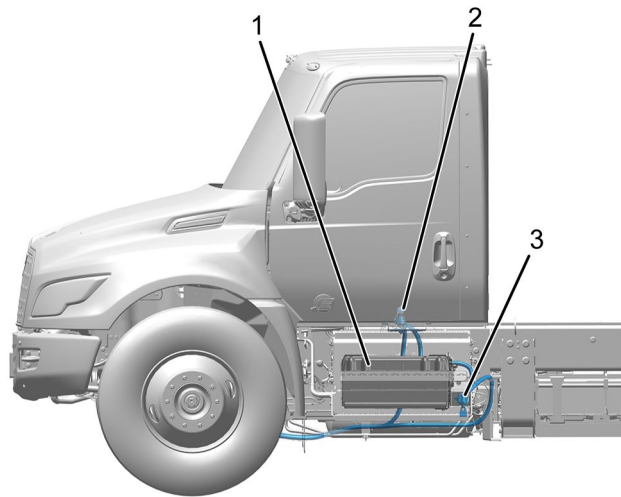

0000469837

Figure 9. 12V and High-Voltage Disconnect Switch

1. 12V battery compartment
2. High-voltage disconnect switch (located inside of cab)
3. 12V disconnect switch

The high-voltage disconnect switch and 12V disconnect switch (Figure 9, Items 2 and 3) are located on the driver side of the vehicle.

High-Voltage Batteries

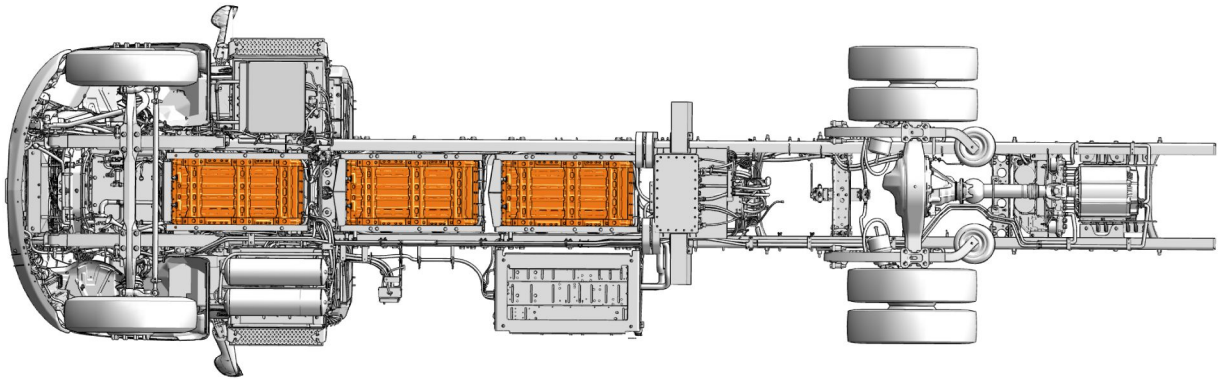

0000470812

Figure 10. High-Voltage Batteries (Viewed from Under Vehicle)

The International® eMV™ Series is equipped with three high-voltage battery stacks. Each stack contains two vertically stacked high-voltage batteries. The high-voltage batteries are between the vehicle frame rails, both under the cab and to the rear of it.

Drive Motor

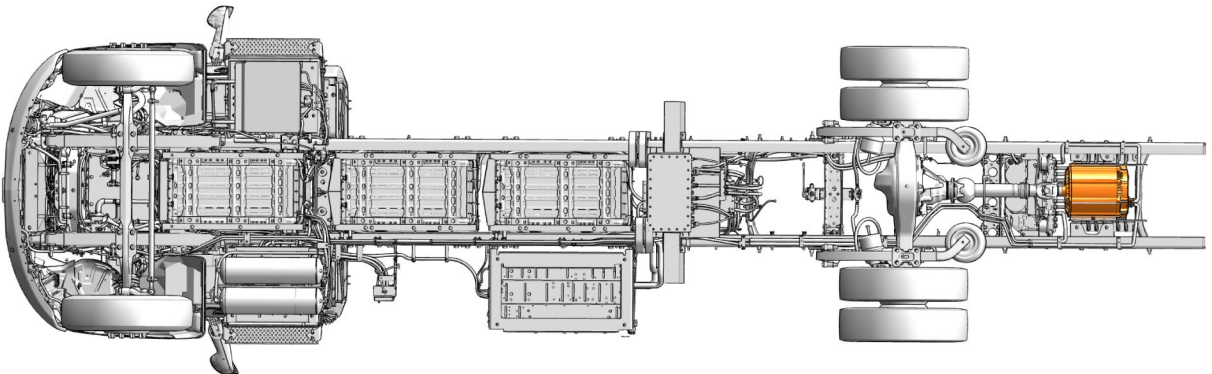

0000470813

Figure 11. Drive Motor (Viewed from Under Vehicle)

The drive motor is located behind the rear axle and is powered by 6-phase alternating current (AC). The drive motor and the differential are connected by a drive shaft.

High-Voltage Cables

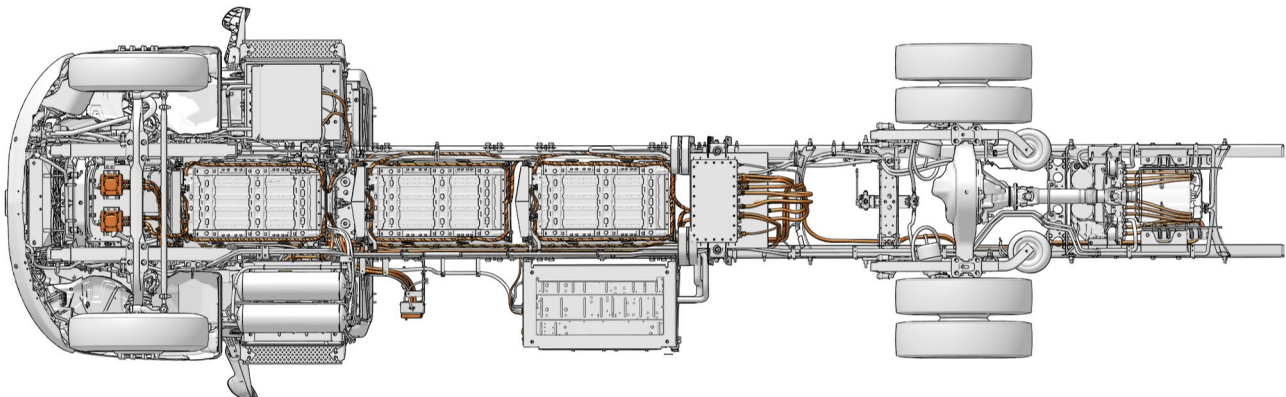

0000470814

Figure 12. High-Voltage Cables (Viewed from Under Vehicle)

⚠ WARNING: To prevent personal injury and / or death, NEVER cut or attempt to breach high-voltage batteries, high-voltage components, or high-voltage cables when high voltage is present.

High-voltage cables are colored in ORANGE and / or ORANGE with stripes. DO NOT cut, breach, or stress ORANGE high-voltage components unless high-voltage in the corresponding zone has been isolated:

- High voltage in Zone 1 is isolated when Level 1 Manual Service Disconnects (MSDs) are disconnected.
- High voltage in Zone 2 is isolated when Level 2 MSDs are disconnected.
- NEVER cut or attempt to breach high-voltage batteries, high-voltage components, or high-voltage cables in Zone 3.

Refer to *Disable Direct Hazards* on the following pages for detailed instructions.

Disable Direct Hazards

Turning OFF the Vehicle

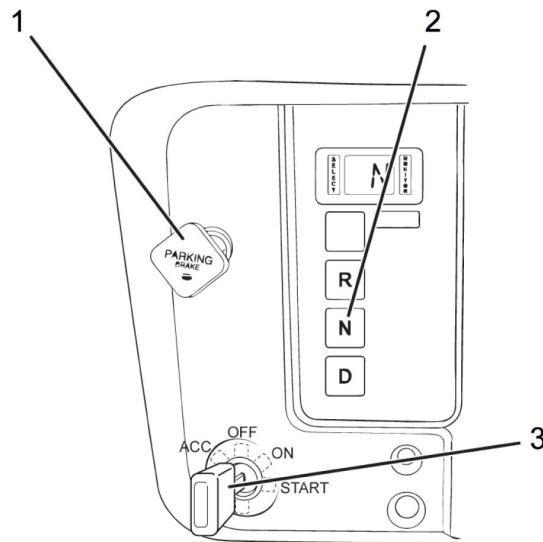

0000469450

Figure 13. Dashboard

1. Parking brake knob (park position)
 2. Neutral selector button
 3. Vehicle key (OFF position)
1. Push Neutral (N) button (Figure 13, Item 2).
 2. Set the parking brake by pulling the parking brake knob (Figure 13, Item 1).
 3. Turn the key (Figure 13, Item 3) to the left to turn OFF the vehicle.
 4. Remove the key.

Disable Direct Hazards (cont.)

Turning Off the High-Voltage Disconnect Switch

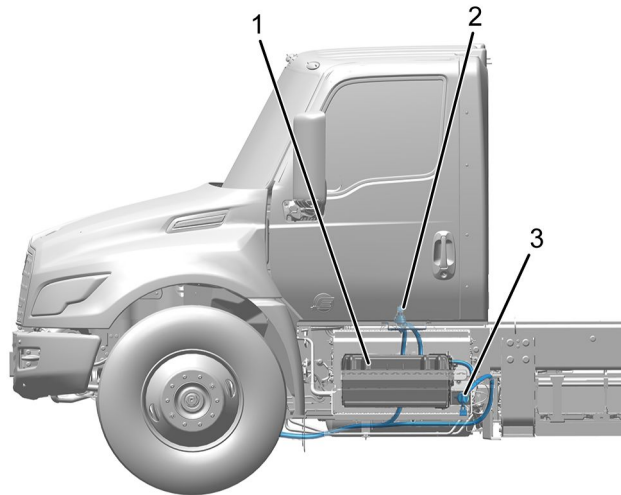

0000469837

Figure 14. 12V and High-Voltage Disconnect Switches

1. 12V battery compartment
2. High-voltage disconnect switch (located inside of cab)
3. 12V disconnect switch

! WARNING: To prevent personal injury and / or death, ALWAYS REMEMBER the high-voltage disconnect switch only disables the vehicle's high-voltage system. The high-voltage disconnect switch does NOT turn OFF the voltage in the S-box, the high-voltage batteries, and the cables between these items. The vehicle 12 volt system could still be energized. ALWAYS turn OFF both the high-voltage disconnect switch and the 12V disconnect switch whenever interacting with a damaged vehicle. NEVER touch ORANGE cables without wearing appropriate Personal Protection Equipment (PPE).

1. Open the driver-side door.
2. Turn the RED high-voltage disconnect switch to OFF position (Figure 14 Item 2).
3. Lock the switch with a padlock to avoid anyone from turning it back ON.

Components in high-voltage zone 2 and high-voltage zone 3 remain live after the high-voltage disconnect switch is turned OFF. These zones are located primarily between the frame rails on the underside of the vehicle and are labeled as indicated in Figure 4.

Disable Direct Hazards (cont.)

Turning Off the 12V Battery Disconnect Switch

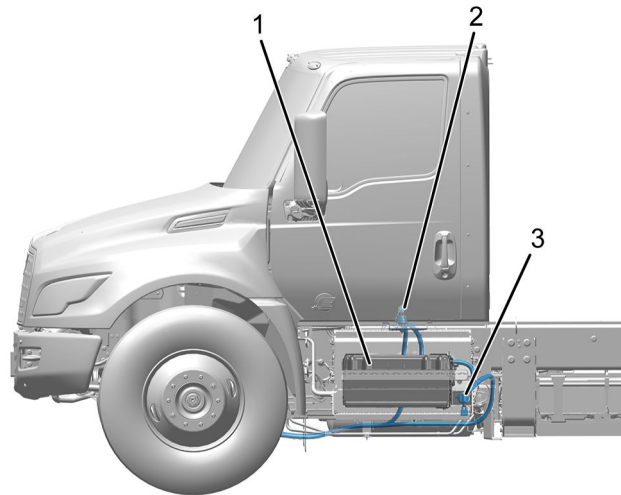

0000469837

Figure 15. 12V and High-Voltage Disconnect Switches

1. 12V battery compartment
2. High-voltage disconnect switch (located inside of cab)
3. 12V disconnect switch

⚠ WARNING: To prevent personal injury and / or death, turn OFF the high-voltage disconnect switch first and then turn OFF the 12V disconnect switch before interacting with a damaged vehicle.

⚠ WARNING: To prevent personal injury and / or death, ALWAYS REMEMBER the 12V disconnect switch only disables the vehicle 12 volt system, NOT the high-voltage battery system.

1. Turn the RED 12V disconnect switch to OFF position (Figure 15, Item 3).
2. Lock the switch with a padlock to avoid anyone from turning it back ON.

Disable Direct Hazards (cont.)

Disconnecting Manual Service Disconnects (MSD)

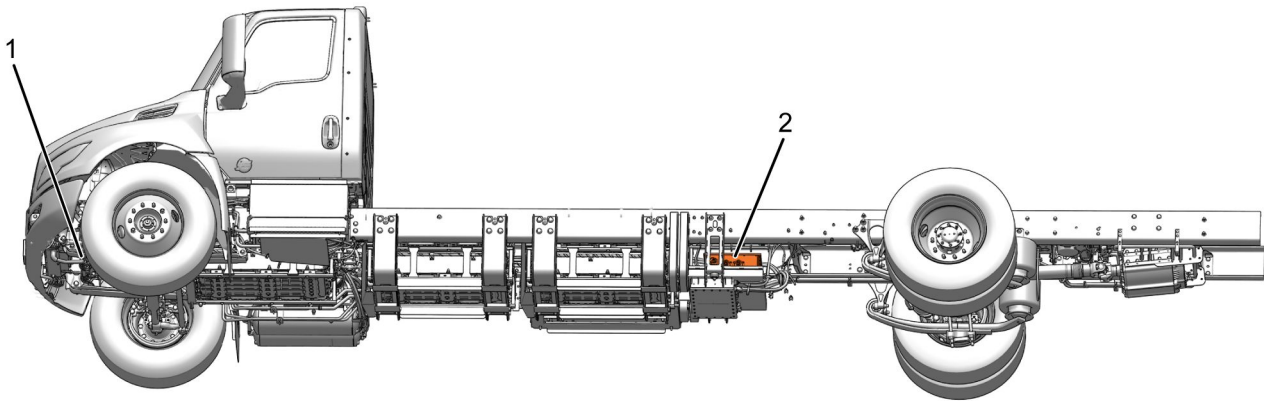

0000471166

Figure 16. MSD Locations

1. Level 2 MSDs
2. Level 1 MSDs

There are two sets of MSDs on the vehicle. They should be disconnected in the following order:

1. The level 1 MSDs, located on the S-box (Figure 16, Item 2).
2. The level 2 MSDs, located on the underside center of the vehicle (Figure 16, Item 1).

Disable Direct Hazards (cont.)

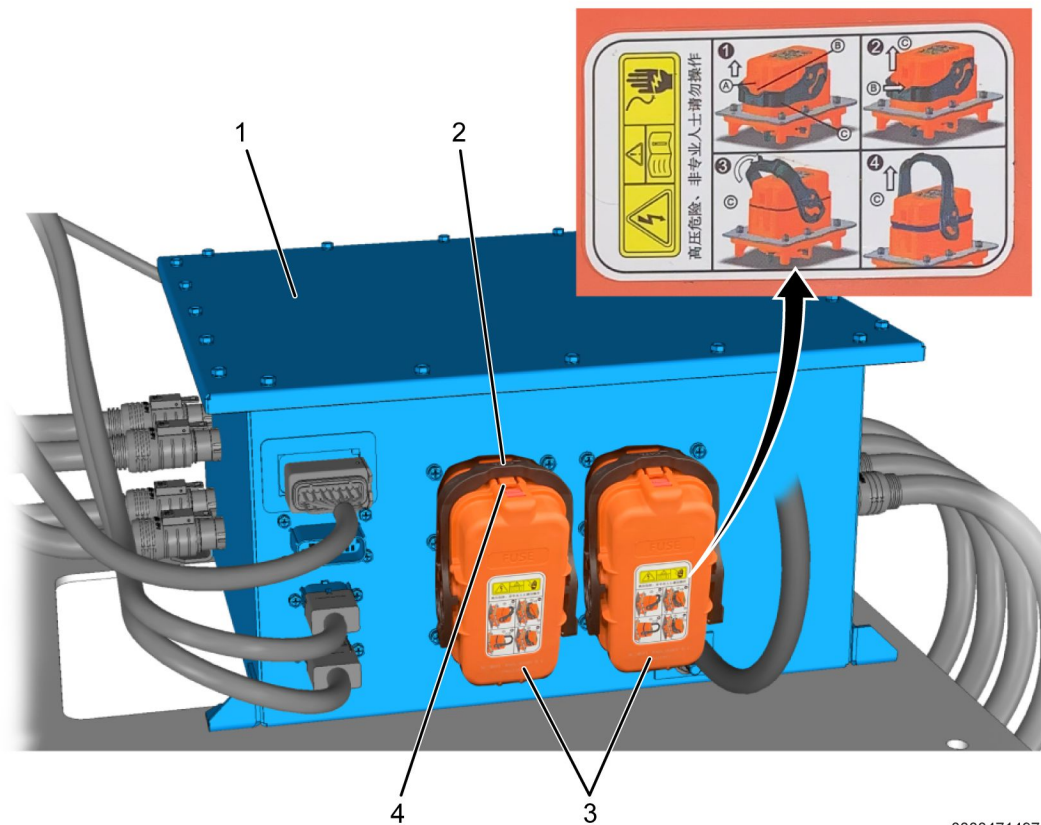

0000471497

Figure 17. Level 1 Manual Service Disconnects (MSDs)

1. S-box
2. Lever release tab
3. MSD (2 total)
4. Red locking tab

The Level 1 MSDs (Figure 17, Item 3) are located on the S-box (Item 1) and can be accessed from the driver side of the vehicle.

Each level 1 MSD can be removed by pulling the RED locking tab (Item 4) out, pressing the lever release tab (Item 2), and then pulling the release handle downward approximately 45 degrees.

Removing these two MSDs physically disconnects high voltage after the S-box, isolating high voltage away from high-voltage isolation zone 1. High voltage will still exist in high-voltage isolation zones 2 and 3.

Disable Direct Hazards (cont.)

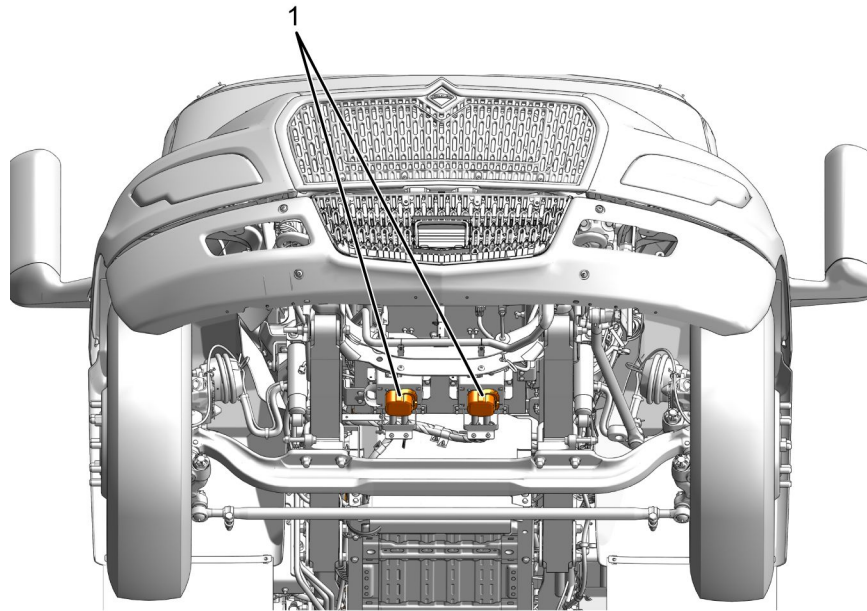

0000471159

Figure 18. Level 2 Manual Service Disconnects (MSDs)

1. MSD (2)

The Level 2 manual service disconnects (Figure 18, Item 2) are located under the vehicle, just forward of the front axle.

Each Level 2 MSD can be removed by pulling out the RED locking tab while pulling the release handle down approximately 45 degrees.

Removing these two MSDs physically disconnects high voltage between the S-box and the battery stacks, isolating high voltage away from high-voltage isolation zone 2. High voltage will still exist in high-voltage isolation zone 3 (the HV batteries and level 3 cables).

Stored Energy / Liquids

Lithium iron phosphate batteries are used in the high-voltage system. These cells are dry cells. Most of the electrolyte stored in these batteries is absorbed by active materials. There is only a small amount of fluid, which may leak if damaged. Leaking electrolyte will occur in drops, not puddles. The fluid is clear in color with a sweet ether-type odor. The smell may indicate a battery leak. Call the fire department immediately.

The high-voltage batteries, on-board chargers, DC-DC converters, Traction Power Inverter Module (TPIM), and drive motor are liquid cooled with a glycol-based automotive coolant. This liquid is RED in color and may leak in case of a damaged cooling system.

Hazardous Material Emergency Cleanup

Following an electric vehicle accident / incident, hazardous materials need to be cleaned up appropriately. Please contact your local and state authorities for more information regarding proper response and cleanup of hazardous materials.

In Case of Fire

 **WARNING: To prevent personal injury and / or death, always wear full Personal Protection Equipment (PPE), including Self-Contained Breathing Apparatus (SCBA) when fire is involved. Fires in crash-damaged electric vehicles could emit toxic or combustible gasses. Small amounts of eye, skin, or lung irritants may be present. If exposed, rinse with large amounts of water for 10-15 minutes. Consider the entire vehicle as energized.**

 **WARNING: To prevent personal injury and / or death, pay attention to secondary fire events. There is a high risk of reignition after fire is extinguished.**

Flames, smoke, arcing or hot spots like melted plastic may indicate fire or the presence of high voltage. A thermal camera or IR temperature probe may be useful to identify hot spots. If signs of fire are noted, call the local fire department immediately. Clear the area around the vehicle if possible and open the vehicle doors to avoid build-up of gases in the passenger compartment. If a battery has started burning, it will try to burn to completion. Cool down the batteries with direct and large amounts of water. If possible, remove combustible materials from around the vehicle to prevent fire growth.

Batteries must be completely cooled down before releasing the vehicle to second responder. Advise second responder that there is always a risk of reignition.

In Case of Submersion

In case of submersion, secondary impact damage can never be excluded. Damaged high-voltage components pose an increased electrical shock hazard. Stay away from damaged high-voltage components. Handle any fully or partially submerged vehicle while wearing the appropriate Personal Protection Equipment (PPE).

A submerged vehicle **without** impact damage has a low electrical shock hazard risk. Small bubbles may be noticed exiting the vehicle. This is due to electrolysis of the water and does not create a higher risk of shock hazard.

 **WARNING: To prevent personal injury and / or death, consider the entire vehicle as energized. Always wear full Personal Protection Equipment (PPE).**

 **WARNING: To prevent personal injury and / or death, pay attention to secondary fire events. There is a high risk of reignition due to damage and corrosion. Saltwater increases this risk for electrical shorts post incident. Keep full Personal Protection Equipment (PPE), including Self-Contained Breathing Apparatus (SCBA) ready.**

 **WARNING: To prevent personal injury and / or death, avoid any contact with a submerged high-voltage system. Do not attempt to disable the High-Voltage Service Disconnect switch while the vehicle is submerged. The ignition may be turned OFF.**

1. Turn the vehicle OFF (if possible).
2. Recover the vehicle.
3. Drain the water out of the vehicle.
4. Turn the high-voltage disconnect switch to the OFF position.

Towing / Transportation / Storage

Towing

The preferred method is to tow the vehicle with the front wheels suspended. If towed with the rear wheels on the ground, the drive shaft / propeller shaft must be removed between the drive motor and rear axle.

To improve traffic safety, the International® eMV™ Series may be slowly (maximum of 5 mph [8 km/h]) moved anytime over very short distances. The electric drive motor is connected to the wheels and generates electric voltage as the wheels are rotated. Higher speed could cause damage to the drive motor, the high-voltage system and represents a potential hazard.

Transportation

Inform the tow truck driver that reignition is possible at any time with a damaged high-voltage system. If possible, use a thermal or infrared camera to check whether the battery stacks are cold before towing the truck. To ensure that electric motor is not rotating, remove the drive shaft / propeller shaft before towing the vehicle to the next location.

Storage

Damaged vehicles should be isolated outdoors until inspected. Open windows and doors during isolation to avoid build-up of gases in the compartment. Separate the vehicle from all combustibles and structures by a distance of at least 50 ft (15 m).



WARNING: To prevent personal injury and / or death, pay attention to secondary fire events. Even days later secondary fire events cannot be excluded.

Please note, high voltage may still be present in high-voltage batteries and cables in Zone 3. To eliminate high-voltage entirely, refer to high-voltage battery Removal procedures located in the eMV Technician Manual.

Important Additional Information

Additional information about accident assistance and recovery of vehicle with high-voltage systems can be found at:

- www.nfpa.org/Training-and-Events/By-topic/Alternative-Fuel-Vehicle-Safety-Training
- www.vda.de/en/services/Publications/rescue-and-towing-of-vehicles-with-high-voltage-systems.html
- SAE J2990 Hybrid and EV First and Second Responder Recommended Practice
- National Transportation Safety Board (NTSB) www.nts.gov